

Change description

See CI 9972

Document Release Status

RELEASED

Release Date
2006-12-12

Version
1

E-CIRCLIPS

Spring steel
Electroplated based on zinc-nickel, black
As per ELV directive

1 REQUIREMENTS

1.1 Material

Spring steel, hardened and tempered HRC 44 – 48.

1.2 Surface treatment

Treated ZnNi black passivated Y200-3 color black VCS 5737,29

1.3 Others

Free from burrs, sharp edges and other defects which may lessen the usability.

Symbols, designations and general drawing methods VCS 5023,509.

Part must comply with restricted substance management standard: WSS-M99P9999-A1 to help safeguard health, safety and the environment.

The copying, distribution and utilization of this document as well as the communication of its contents to others without expressed authorization is prohibited. Offenders will be held liable for payment of damages. All rights reserved in the event of the grant of a patent, utility model or ornamental design registration.

Document Name
E-CIRCLIP

Document Type
MULTI-PART DRAWING

FMC Part No
-W713277-S900

Document No	Revision	Volume No	Page No (In this doc.)
01055387	002	01	1 (3)

VOLVO

Volvo Car Corporation

Dimensions

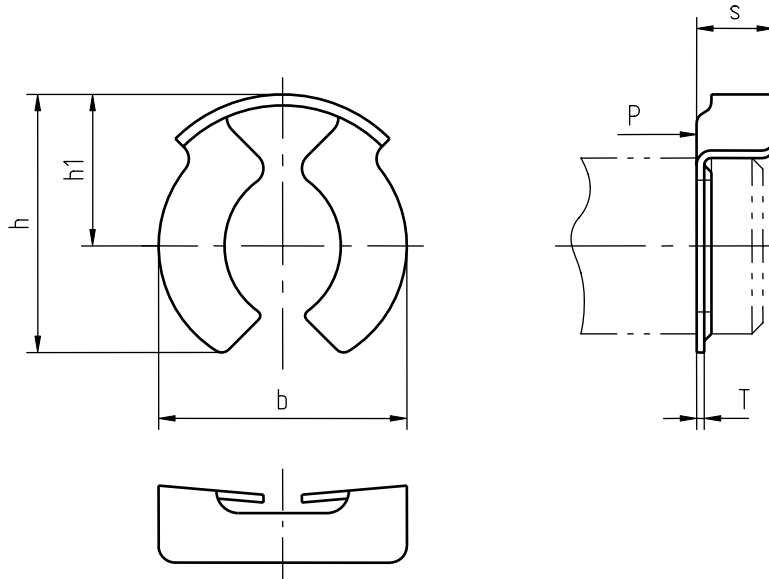

Fig. 1

d Shaft diam.	T ±0,05	b ≈	h ≈	h1 ≈	s ≈	P max N	Part No.
4	0,4	6,8	7	4,3	2,6	1500	989043
5	0,5	7,7	8,4	5,2	2,8	3000	989044
6	0,6	10,6	11,2	6,8	3,5	4850	989045
8	0,6	11,5	11,8	7,2	4	5500	989046
10	0,65	16	15,7	9,5	5	9500	989047
12	0,65	17	17,5	10,5	6	10700	989048
14	0,7	20	20	11,5	6,7	12700	989049
16	0,7	22,6	23,5	13,8	7	14000	989050

VOLVO

Volvo Car Corporation

Document Name

E-CIRCLIP

Document Type

MULTI-PART DRAWING

Document No

01055387

Revision

002

Volume No

01

Page No (In this doc.)

2 (3)

2 INSTRUCTIONS

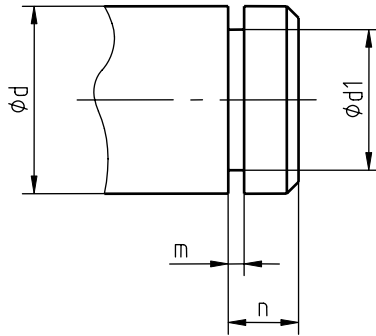

Fig. 2 Shaft end

d Shaft diam.		d1		m	n
nom	min	nom	tol	$\pm 0,05$	min
4	3,925	3,2	$\pm 0,05$	0,64	2
5	4,925	4	$\pm 0,05$	0,74	2,5
6	5,925	5	$\pm 0,05$	0,74	3
8	7,91	6	$\pm 0,05$	0,94	3,5
10	9,91	8	$\pm 0,1$	1,05	4,5
12	11,89	9	$\pm 0,1$	1,15	5
14	13,89	10	$\pm 0,1$	1,25	5,5
16	15,89	12	$\pm 0,1$	1,35	6

VOLVO

Volvo Car Corporation

Document Name

E-CIRCLIP

Document Type

MULTI-PART DRAWING

Document No

01055387

Revision

002

Volume No

01

Page No (In this doc.)

3 (3)